

IP Multicast

September 20, 2001

Overview

- applications
- models
- host APIs
- LAN (IGMP, LAN switches)
- intra-domain routing
- inter-domain routing
- address allocation

Additional references (some are dated!):

- Stephen A. Thomas, *IPng and the TCP/IP protocols*, Wiley, 1996.

September 20, 2001

- Christian Huitema, *Routing in the Internet*, Prentice Hall, 1995.
- Crowcroft/Handley/Wakeman, *Internetworking Multimedia*, 2000.

Partially drawn from <http://www-scf.usc.edu/~dbyrne/960223.txt> (D. Estrin)

September 20, 2001

Broadcast and multicast

broadcast: all hosts on (small, local) network

directed broadcast: all hosts on remote network

multicast: multiple recipients (group)

September 20, 2001

Applications for Multicast

- audio-video distribution (1-to-many) and symmetric (all-to-all)
- distributed simulation (war gaming, multi-player Doom, ...)
- resource discovery (where's the next time server?)
- file distribution (stock market quotes, new software, ...)
- network news (Usenet)

September 20, 2001

Multicast trees

spanning tree \equiv tree that connects all the vertices (hosts/routers)

shared tree: single tree for *all* sources S

- minimum-cost spanning (MST) tree (where cost = hops, delay, \$, ...)
- does not minimize length of S to individual destination
- all traffic concentrated on tree \Rightarrow reservation failures

per-source tree: build independently for each source \Rightarrow many variations!

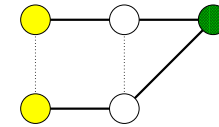

September 20, 2001

Steiner Tree

Minimizes the total number of links for all sinks

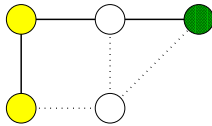

N-P complete (travelling salesman), unstable: small additions \rightarrow large changes in traffic flows

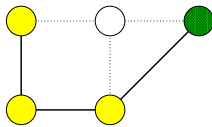

Add one node:

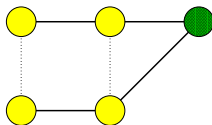

September 20, 2001

Finding MST via Prim's Algorithm

- centralized, finds MST for $G = (V, E)$
- U : set of vertices connected, start with one
- add lowest-cost edge (u, v) with $u \in U$ and $v \in V - U$.
- $T \leftarrow T \cup (u, v)$
- $U \leftarrow U \cup v$

September 20, 2001

Connection-oriented multicast

- enumerate sources explicitly \Rightarrow source-based trees
- examples:
 - ATM \Rightarrow explicitly add each end point
 - ST-II \Rightarrow enumerate end points in setup message
 - ATM, ST-II: end nodes attach themselves to tree
 - enumeration of end points in packet
- only connection-oriented (packet header size!)
- source needs to know destinations \leftrightarrow resource discovery, dynamic groups difficult
- but: natural transition from unicast to multicast

September 20, 2001

ST-II

- IEN 199: ST \Rightarrow ST-II: RFC 1190 (1990) \Rightarrow ST-II+: RFC 1819 (1995)
- hard state
- combines building tree with resource reservation
- first Internet resource allocation protocol
- sender-initiated tree \Rightarrow receiver-initiated joins ST2+

September 20, 2001

Host group model

Deering, 1991:

- senders need not be members;
- groups may have any number of members;
- there are no topological restrictions on group membership;
- membership is dynamic and autonomous;
- host groups may be transient or permanent.

September 20, 2001

Local multicast

Some local networks are by nature multi/broadcast: Ethernet, Token Ring, FDDI, . . .

Ethernet, Tokenring:

- broadcast: all ones
- multicast: 01.xx.xx.xx.xx.xx
- adapter hardware can filter dynamic list of addresses

ATM: point-to-point links \Rightarrow need ATM multicast server

September 20, 2001

IP multicast

- host-group model
- network-level; data packets same, only address changes
- need help of routers
- special IP addresses (class D): 224.0.0.0 through 239.255.255.255
- 28 bits \Rightarrow 268 million groups (plus scope)
- 224.0.0.x: local network only \Rightarrow 224.0.0.1: all hosts; 224.0.0.2: all routers
- some pre-assigned (224.0.1.2: SGI Dogfight)
- others dynamic (224.2.x.x for multimedia conferencing)
- map into Ethernet: 01.00.5E.00.00.00 + lower 23 bits
- ttl value limits distribution: 0=host, 1=network

September 20, 2001

Administrative Scoping

- address-based
- 239.255/16: IPv4 local scope
- 239.192/14: organization local scope
- relative addresses (from top) for common applications within scope

September 20, 2001

Multicast programming

UDP, not TCP (obviously...)

```
struct sockaddr_in name;
struct ip_mreq imr;

sock = socket(AF_INET, SOCK_DGRAM, 0);
imr.imr_multiaddr.s_addr = htonl(groupaddr);
imr.imr_interface.s_addr = htonl(INADDR_ANY);
setsockopt(sock, IPPROTO_IP, IP_ADD_MEMBERSHIP,
    &imr, sizeof(struct ip_mreq));
name.sin_addr.s_addr = htonl(groupaddr);
name.sin_port = htons(groupport);
bind(sock, &name, sizeof(name));
recv(sock, (char *)buf, sizeof(buf), 0);
```

September 20, 2001

IGMP

Multicast for local (*broadcast*) networks, between router and hosts

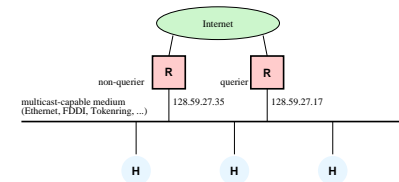

- router listens to all multicast packets on all interfaces
- hosts sends IGMP report for first process to join group to that multicast group (ttl=1), maybe repeat
- router multicasts query to all hosts (224.0.0.2) \approx every 125 seconds or on start-up
- host waits and listens for others; if nobody else, send response for groups it's in

September 20, 2001

- if “responsible” for group, notify “all router” group → querier sends group-specific query → reduce bandwidth consumption
- random interval determined by router (< 10 seconds)
- really appropriate for today’s switched Ethernet?

IGMPv2 timing

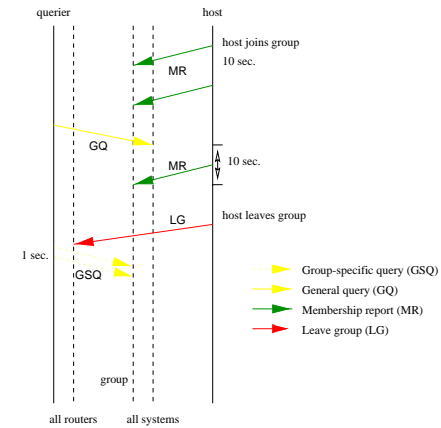

IGMPv2 packet

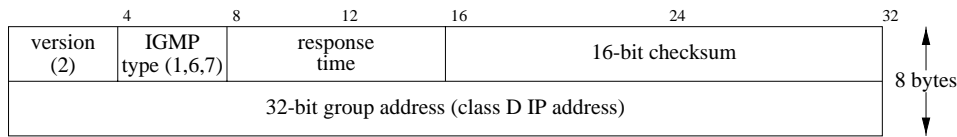

```
$ netstat -g
Group Memberships
Interface Group                RefCnt
-----
lo0      ALL-SYSTEMS.MCAST.NET      1
le0      224.2.127.255              1
le0      ALL-SYSTEMS.MCAST.NET      1
```

IGMPv3

- adds source filtering to IGMPv2
- Membership Report includes lists of sources to include or exclude
- Group-and-Source-Specific Query asks whether anybody cares about the group and the sources listed
- unlike IGMPv2, host no longer suppresses membership reports if it hears from another host
 - accounting
 - avoid Ethernet switches having to remove “outbound” IGMP reports to fool hosts
 - for efficiency, single membership report can list multiple groups

Note: IPv6 defines new protocol, Multicast Listener Discovery (MLD)

Reverse path flooding

iif: incoming interface; oif: outgoing interface

- if iif is on shortest path to source S
- forward to all other oifs (*RPF check*) towards receivers R in group G
- avoids forwarding duplicates

September 20, 2001

Multicast forwarding

First packet (truncated broadcast)

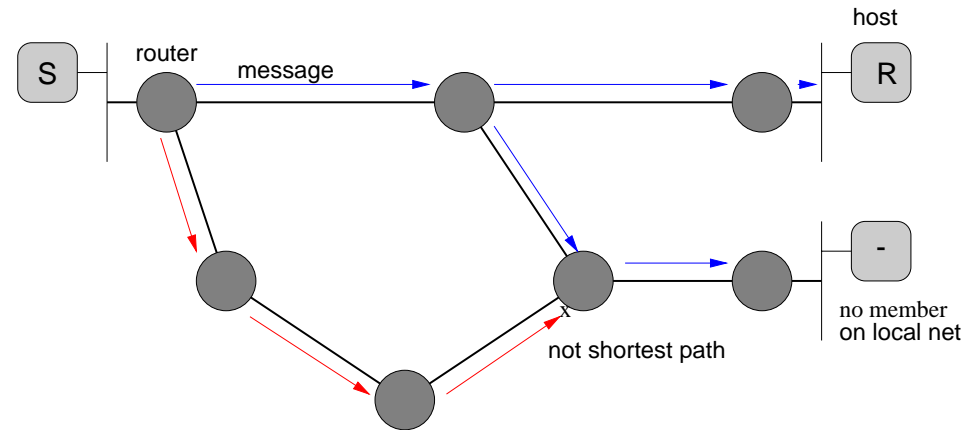

September 20, 2001

Reverse path broadcasting

- do RPF check as before
- exchange unicast routing info to establish "parentage"
- restrict oifs to child nodes

▮ reduce duplicates

September 20, 2001

Multicast routing

- link-state based
- dense mode
- sparse mode

September 20, 2001

Multicast forwarding with truncation

- flood with RPF check
- pruning: leaves of tree send “prune” if no members below
- receivers tell routers of membership
- routers know whether to forward to LAN or prune
- prune state must time out \Rightarrow periodic broadcast
- trade-off: join latency \leftrightarrow bandwidth
- add: explicit “graft” to cancel prune: \Rightarrow join latency \downarrow
- still need occasional broadcast for topology changes

September 20, 2001

Multicast forwarding

With pruning:

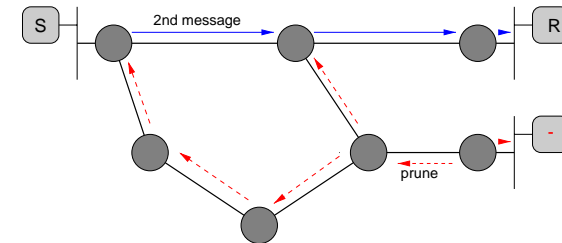

\Rightarrow router needs to keep “negative” list for groups

September 20, 2001

Distance Vector Multicast Routing Protocol (DVMRP)

- flood + RPF check
- pruning: time out 1 minute
- routers may send *grafts* upstream
- only send to children
- maintain routing information (DV)
- used in old Mbone overlay network

September 20, 2001

Multicast Open Shortest Path First (MOSPF)

- link-state based
- include membership info in link-state advertisements
- compute tree for each S, G pair \Rightarrow oifs
- can create shortest-path trees even with asymmetric links
- cannot afford to recompute trees with each LS change

September 20, 2001

PIM-DM

- use unicast routing table
- DVMRP: include only oif that use this router to reach source
- PIM-DM: forward to all outgoing interfaces

September 20, 2001

Problems

- “multicast storms”
 - MOSPF: broadcast of membership to off-tree areas
 - DVMRP: occasional broadcast of packets \Rightarrow bad for WANs
 - prune state in routers for sparse groups
 - multicast routing vs. unicast routing: reverse path with asymmetric links
 - hierarchical routing?
 - few “big” senders, lots of background mumbling
- \Rightarrow compromise on optimal trees

September 20, 2001

Protocol Independent Multicast (PIM-SM)

- uses unicast routing
- supports SPTs and shared trees (rooted at “rendezvous point” RP), depending on traffic
 1. group-specific RP-rooted shared tree
 2. source-based tree

September 20, 2001

PIM-SM: RP election

- RP selected by hash of G
- bootstrap router (BSR) candidate sends list of candidate RPs
- candidate BSRs, configured with priority
- multicast candidacy locally (ttl = 1), then flood
- elected routers periodically sends bootstrap message with RPs
- {candidate BSR} \approx {candidate RP}
- candidate-RP sends message to BSR

September 20, 2001

PIM-SM: shared tree

- send packet via unicast in “register” message, encapsulated, to RP
- RP forwards message down shared tree
- receivers send “join” to RP to join shared tree
- joins stop when reaching tree, install $(*, G)$ state

September 20, 2001

PIM-SM: source-specific tree

1. bypass encapsulation
 - RP sends “join” towards S
 - nodes recognize destination and forward based on G
2. receivers join
3. and prune shared tree for S

September 20, 2001

PIM-SM

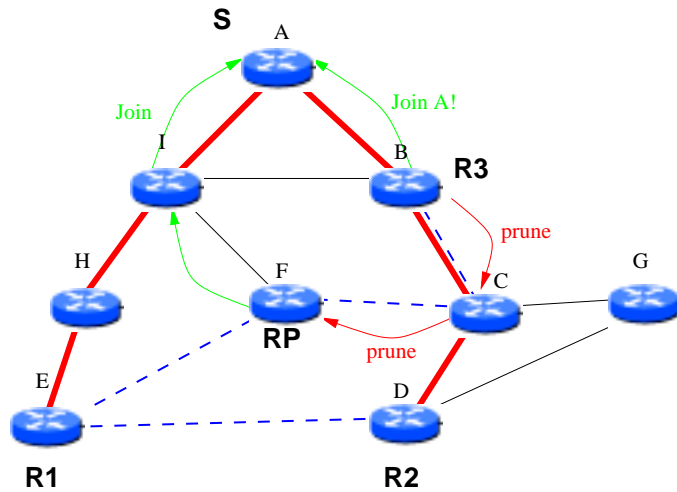

September 20, 2001

Sparse Mode Problems

- single point of failure
- hot spot
- non-optimal path
- complexity

September 20, 2001

Interdomain sparse multicast routing: CBT

- core-based trees: bidirectional center-based shared trees routed at *core*
- receivers send join messages to core
- senders send data to core, but can be short-cut → send to all interfaces participating in group
- no SPTs
- *hard-state* with acknowledged join from core or first on-tree router
 - + : no source specific state
 - : path lengths, traffic concentration
- explicit joining (vs. implicit join and explicit prune)
 - join messages from *R*'s router to root of tree
- not much implementation

September 20, 2001

MBONE

- MBONE \equiv multicast backbone
- overlay network over Internet, up to 10,000 routes
- difficulty of limiting fan-out
- needed until deployment of multicast-capable backbone routers
- IP-in-IP encapsulation \Rightarrow *tunneling*:

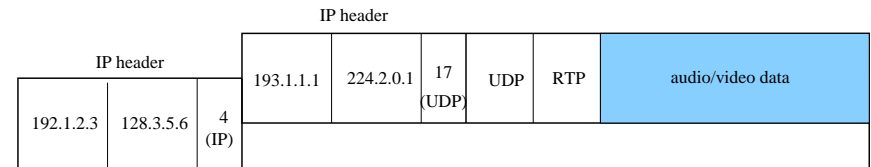

source: 193.1.1.1; group: 224.2.0.1; MBONE tunnel: 192.1.2.3 to 128.3.5.6

- limited capacity, resilience

September 20, 2001

Mbone

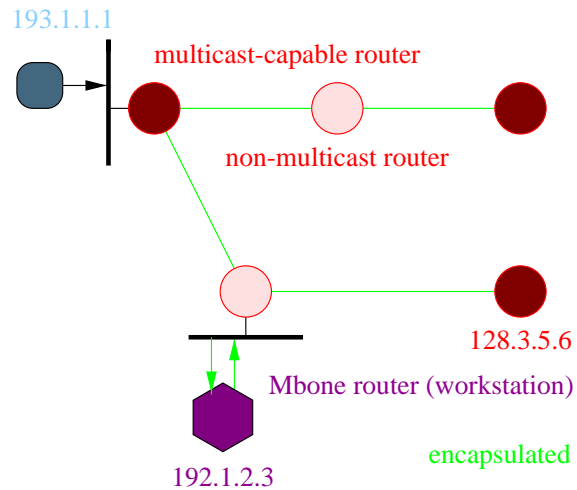

September 20, 2001

Inter-domain multicast

- one RP per AS
- use intra (interior) routing protocol, like PIM-SM or DVMRP
- two approaches to scaling:
 - short term: MSDP = distribution of sender information
 - longer term: BGMP = shared inter-domain tree

September 20, 2001

Multicast Source Discovery Protocol (MSDP)

- join together PIM-SM regions (“AS”)
- RPs use MSDP to discover sources in other regions
- and can send them them PIM “join” requests if there are local receivers
- thus, each inter-domain source gets source tree

September 20, 2001

MSDP Operation

- MSDP RPs peer with fellow RPs via TCP
- periodically send “source active” to peer RPs: (source address, group, RP)
- flood “source active” message in RPF style
- peers can aggregate messages
- first few data messages can be exchanged via MSDP peers (encapsulated)
- works reasonably well only when few senders

September 20, 2001

MSDP Operation

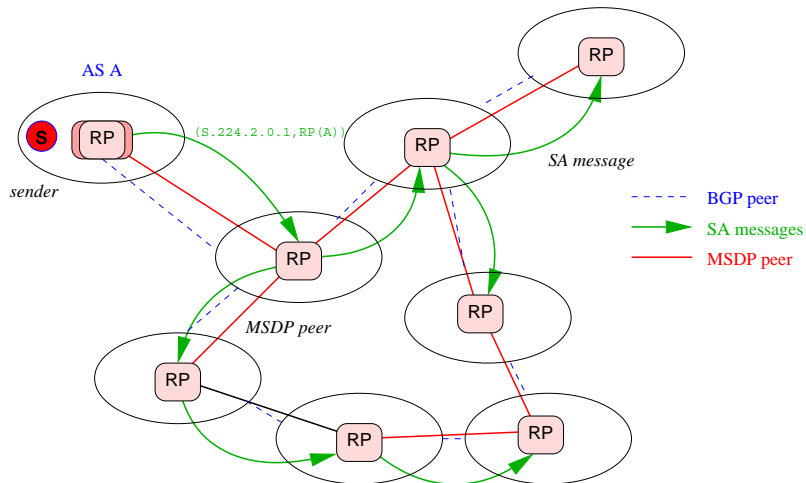

September 20, 2001

Border Gateway Multicast Routing Protocol (BGMP)

- *bidirectional* shared tree for each group
- TCP connections between routers (external BGP peers)
- root domain
- distribute “routes” to AS hosting core
- packets can bypass BGMP core
- packet forwarding similar to PIM-SM RP

September 20, 2001

BGMP

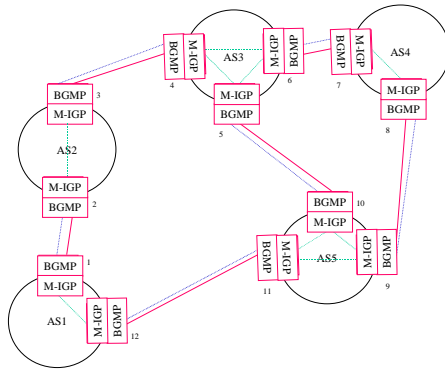

September 20, 2001

Multicast address allocation

hierarchical, with different time scales:

1. intra-domain, clients contact local MAAS server in domain via MADCAP
2. MAAS gets it via Multicast Address Allocation Protocol (AAP) from MASC
 - MASC routers multicast availability to the MAAS
 - MAAS multicast claims
3. MASC divide space for inter-AS for large blocks

bypass inter domain: assign 233/8 for per-AS static allocation

September 20, 2001

Multicast Address Allocation

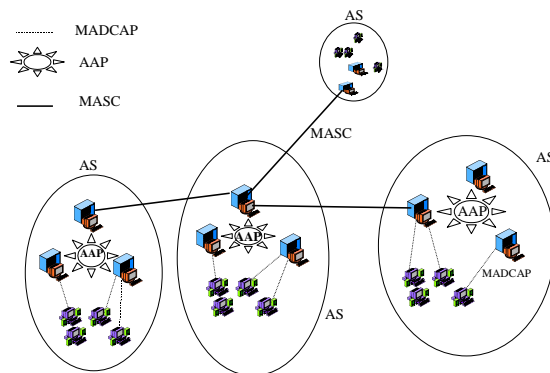

September 20, 2001

Multicast Address Dynamic Client Allocation Protocol: MADCAP

RFC 2730

- UDP-based request-response (similar to DHCP)
- one or more local servers
- may request addresses in the future
- specify maximum delay
- can request specific address
- discover scopes via INFORM
- multicast request via DISCOVER
- server hands out, client confirms via REQUEST
- expires or via RELEASE

September 20, 2001

MADCAP

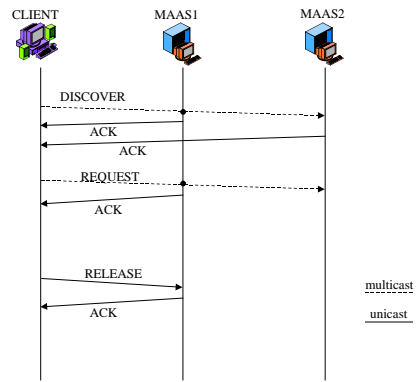

September 20, 2001

AAP: Multicast Addresses within AS

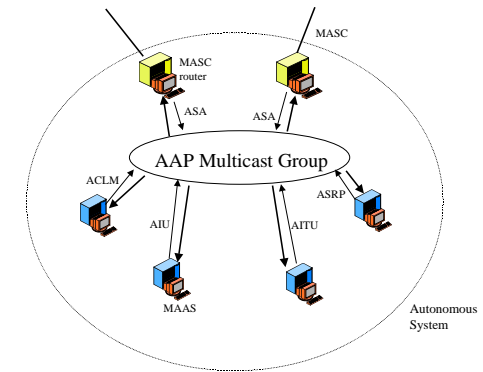

September 20, 2001

AAP

- send ACLM to claim addresses
- object to claims and announce own via AIU
- MAAS can preallocate addresses (ACLM) or “Address Intent to Use” (AITU), with reclaiming by others via ACLM
- report periodically on address space use

September 20, 2001

MASC

- top of hierarchy: inter-domain
- BGP model: TCP peering relationships
- also allows customer-provider relationships
- send time-limited claim for range, wait a few days and then use
- send “prefix managed” to children

September 20, 2001